

ACCESS PORTABLE MIXER

TABLE OF CONTENTS

SECTION 1 *INTRODUCTION*..... 3
..... *WHAT COMES WITH ACCESS MIXER*..... 3

SECTION 2 *INSTALLATION*..... 4

SECTION 3 *ACCESS PORTABLE MIXER CONTROLS AND CONNECTIONS*..... 6

SECTION 4 *ACCESS PORTABLE SET-UP OPTIONS* 8
..... *CONFIGURATION OPTIONS*..... 8
..... *USING ACCESS PORTABLE MIXER WITH BATTERY POWER* 8

SECTION 5 *CONFORMITY INFORMATION*..... 9

FIGURE LISTING *FIGURE 1 - PORTABLE SIDE VIEW*..... 4
..... *FIGURE 2 - DOCKING THE ACCESS PORTABLE* 4
..... *FIGURE 3 - BOTTOM VIEW OF ACCESS PORTABLE & MIXER*..... 5
..... *FIGURE 4 - TOP PANEL DIAGRAM AND DESCRIPTIONS* ... 6
..... *FIGURE 5 - REAR PANEL DIAGRAM AND DESCRIPTIONS* 7
..... *FIGURE 6 - MIXER CONFIGURATION OPTIONS OF ACCESS PORTABLE*..... 8

About Comrex

Comrex has been building reliable, high quality broadcast equipment since 1961. Our products are used daily in every part of the world by networks, stations and program producers.

Every product we manufacture has been carefully designed to function flawlessly, under the harshest conditions, over many years of use. Each unit we ship has been individually and thoroughly tested. Most items are available off the shelf, either directly from Comrex or from our stocking dealers.

Comrex stands behind its products. We promise that if you call us for technical assistance, you will talk directly with someone who knows about the equipment and will do everything possible to help you.

Our toll free number in North America is 800-237-1776. Product information along with engineering notes and user reports are available on our website at www.comrex.com. Our email address is info@comrex.com.

Warranty and Disclaimer

All equipment manufactured by Comrex Corporation is warranted by Comrex against defects in material and workmanship for one year from the date of original purchase, as verified by the return of the Warranty Registration Card. During the warranty period, we will repair or, at our option, replace at no charge a product that proves to be defective, provided you obtain return authorization from Comrex and return the product, shipping prepaid, to Comrex Corporation, 19 Pine Road, Devens, MA 01434 USA. For return authorization, contact Comrex at 978-784-1776 or fax 978-784-1717.

This Warranty does not apply if the product has been damaged by accident or misuse or as the result of service or modification performed by anyone other than Comrex Corporation.

With the exception of the warranties set forth above, Comrex Corporation makes no other warranties, expressed or implied or statutory, including but not limited to warranties of merchantability and fitness for a particular purpose, which are hereby expressly disclaimed. In no event shall Comrex Corporation have any liability for indirect, consequential or punitive damages resulting from the use of this product.

SECTION 1**INTRODUCTION**

The Comrex ACCESS Portable is a remote broadcast tool that provides utility and portability, but has limited audio I/O built-in. The portable includes one mic/line adjustable input on XLR, one stereo line level input on mini jack, and a headphone and line-level stereo output on mini-jack.

The ACCESS Portable Mixer accessory was designed to address these limitations for applications that require multiple audio I/O for remote broadcasts. The unit “docks” to the ACCESS Portable and expands the audio I/O to five mic/line selectable **XLR Inputs** and five stereo **Headphone Outputs** on ¼” jacks.

All ACCESS Portable audio connectors remain active during use of the Mixer, so the total number of **Input/Headphone** connector pairs increases to six.

In addition to these functions, the Mixer includes the following features:

- Stereo Pan controls for the first four input channels.
- Selectable 12V phantom power on all **Mic** inputs.
- Channel 5 selectable for *Producer Mode*, which may be heard in all headphones but not on-air.
- Ability to monitor ACCESS Portable cellphone input on all headphones for cueing.
- Mixer is powered completely by ACCESS Portable, either from external power supply, or integrated battery.
- Separate **Local/Return** output controls for each **Headphone** out.
- Color-coded control knobs for all functions.

*WHAT COMES WITH
ACCESS MIXER*

The following items are shipped with a new ACCESS Mixer:

- (1) Operating manual
- (1) Warranty card (Please fill out and return to Comrex)

SECTION 2

INSTALLATION

ACCESS Portable Mixer is attached to ACCESS Portable as shown in the following steps and figures:

- 1) Power to the portable should be off before docking. Remove the rubber cover from the **Mixer Port** on the portable.

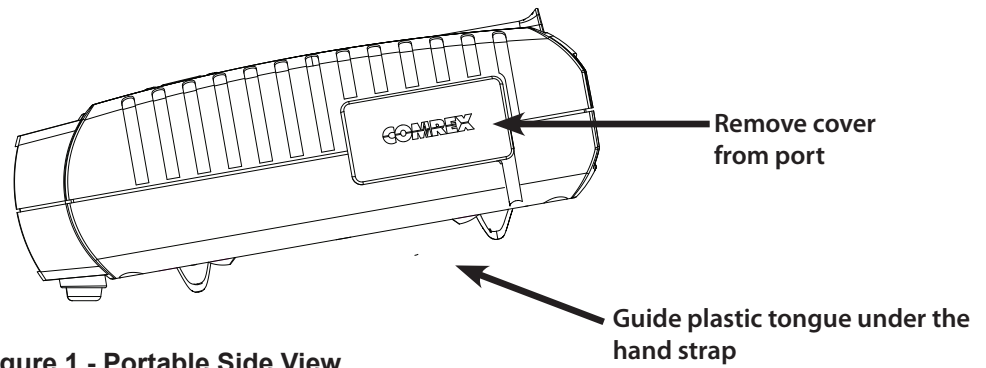

Figure 1 - Portable Side View

- 2) Guide the plastic tongue on the mixer chassis under the flexible hand strap on the portable. Dock the connectors securely together.

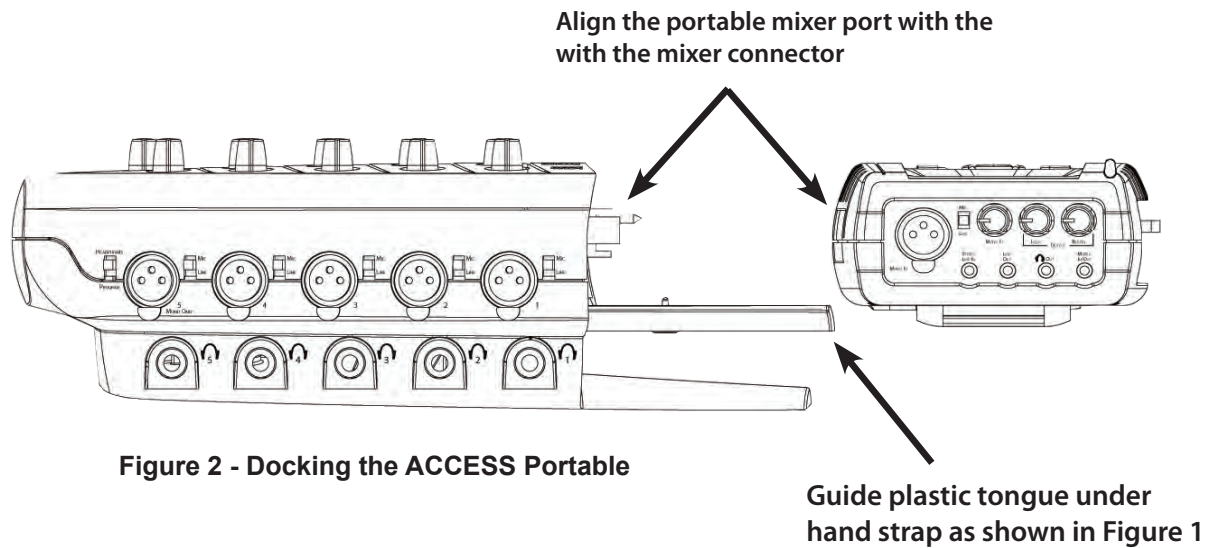

Figure 2 - Docking the ACCESS Portable

- 4) Turn the thumbscrew on the under side of the mixer tongue to secure the units together.

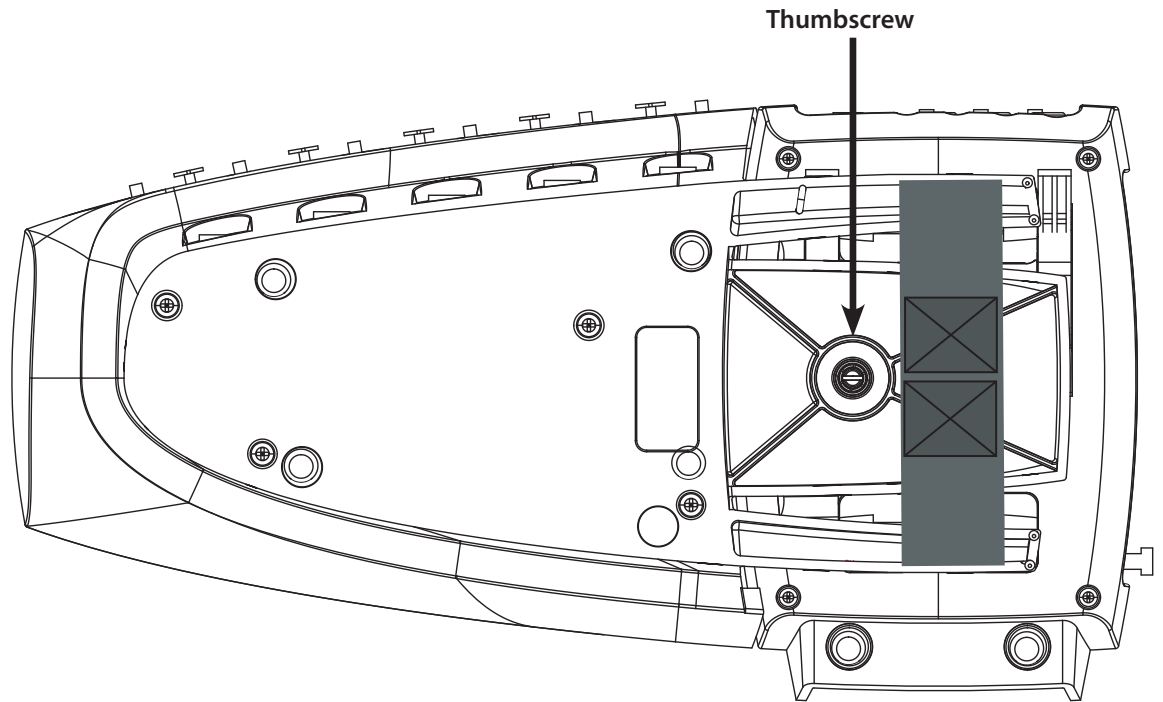
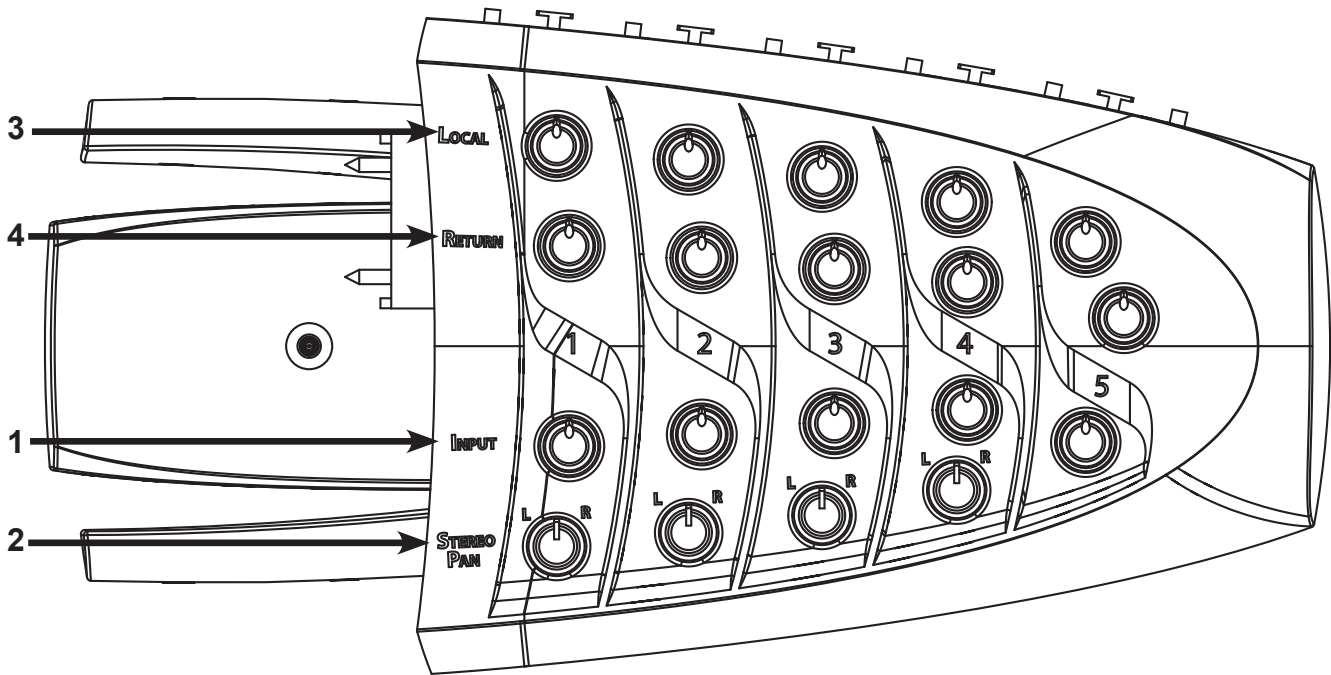

Figure 3 - Bottom view of ACCESS Portable & Mixer

SECTION 3

ACCESS PORTABLE MIXER CONTROLS AND CONNECTIONS

Figure 4 - Top Panel Diagram and Descriptions



1) INPUT LEVEL CONTROL

This knob determines the input level of the signal applied to the respective XLR connector on the rear panel. Use the portable level meter to set this appropriately.

2) INPUT PAN CONTROL

This knob is used for stereo encoder modes. It determines whether the respective input level is centered, or panned left or right in the stereo field. **Input 5** does not have a pan control, and is always centered. *Note: Mono modes utilize left channel input only, so if a signal is panned to the right, it will be low or not present on a mono feed.*

3) HEADPHONE LOCAL CONTROL

Use this knob to determine the amount of locally generated program audio that is applied to the respective headphone output. Local audio is the sum of all inputs of the ACCESS, including those on the portable section.

4) HEADPHONE RETURN CONTROL

This knob determines the amount of non-locally generated audio that is applied to the respective headphone output. This audio is included in the output of the portable decoder (the audio being sent from the studio), producer feed, and mobile phone audio.

Figure 5 - Rear Panel Diagram and Descriptions

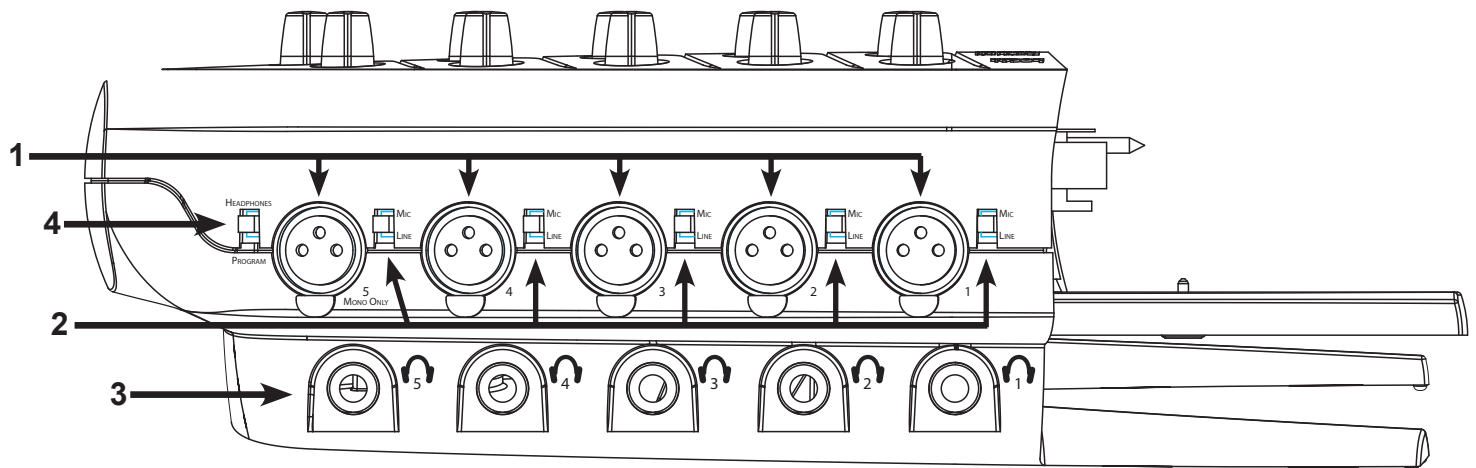
**1) INPUT XLRs**

These are professional balanced inputs pinned as follows:

- Pin 1 Ground
- Pin 2 Audio +
- Pin 3 Audio -

To attach unbalanced sources to these inputs, apply the + audio lead to pin 2, and the shield/ground to both pins 1 and 3.

2) MIC/LINE SWITCHES

Use these switches to set the input level of the respective XLR connector.

3) HEADPHONE JACKS

Five stereo 1/4" jacks deliver a mixture of local and return audio.

4) HEADPHONE/PROGRAM SWITCH

This switch enables a special mode where **Input 5** is taken away from the program mix. In this mode, the audio presented to **Input 5** is fed directly to the headphones, for use as a cue/producer signal to on-air talent.

SECTION 4

ACCESS PORTABLE SET-UP OPTIONS

CONFIGURATION OPTIONS

Figure 6 shows the options available on the **Mixer Audio Configuration Menu** of the ACCESS Portable. This menu is found in the **Configure** section under **Audio Settings**. They are:

Apply phantom power to mic inputs — When this option is selected, 12V phantom power is applied to all the inputs that are switched to mic level. The phantom power is automatically disabled on any line level inputs. This setting will power most condenser/electret microphones. It is not possible to set some mixer microphone inputs to phantom and some not, but the mono input on the portable itself has its own phantom power setting.

Add mobile phone to return feed — When this option is chosen, any audio presented to the portable **Mobile Phone I/O** jack will be added to the **Return** audio available to the mixer headphones. This is a universal setting that adds the signal to all headphones. The **Headphone** jack on the portable has a separate control for this function.

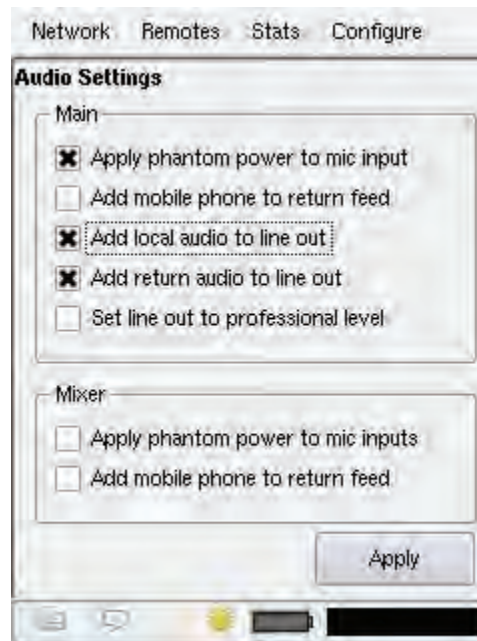

Figure 6 - Mixer Configuration Options of ACCESS Portable

*USING ACCESS PORTABLE
MIXER WITH BATTERY POWER*

The use of the mixer on ACCESS Portable has a significant impact on battery life, especially if multiple, low-impedance headphones are used. In general, battery life of the portable will be cut in half with use of a heavily loaded mixer. We recommend powering the portable from its power supply whenever possible while the mixer is attached. The battery still makes a good temporary backup power source in the case of mains power loss.

SECTION 5

CONFORMITY INFORMATION

*SUPPLIERS' U.S.
DECLARATION OF
CONFORMITY*

Place of Issue: Devens, Massachusetts

Date of Issue: July 2, 2007

Equipment: Comrex ACCESS Portable with Mixer

This equipment has been tested and found to comply with the limits for a Class A digital device, pursuant to part 15 of the FCC Rules. These limits are designed to provide reasonable protection against harmful interference when the equipment is operated in a commercial environment. This equipment generates, uses, and can radiate radio frequency energy and, if not installed and used in accordance with the instruction manual, may cause harmful interference to radio communications. Operation of this equipment in a residential area is likely to cause harmful interference in which case the user will be required to correct the interference at his own expense.

Individual plug-in cards for wired and wireless connectivity will have their own certifications from their manufacturers. Information is available on each card's label.



Thomas O. Hartnett, Technical Director, Comrex Corporation

*EC DECLARATION OF
CONFORMITY FOR
R&TTE DIRECTIVE*

We:

Manufacturer's Name: Comrex Corporation

Manufacturer's Address: 19 Pine Road
Devens, MA 01434
U.S.A.

hereby declare on our sole responsibility that the product:

Comrex ACCESS Portable with Mixer
Digital Audio Codec

to which this declaration relates is in conformity with the essential requirements and other relevant requirements of the R&TTE Directive (1999/5/EC). This product is compliant with the following standards and other normative documents:

European EMC Directive (89/336/EEC)
EN 55022:1998/A1:2000, Class A Conducted and Radiated Emissions
EN55024: 1998/A1:2001/A2:2003 (Immunity, ITE Equipment)
Low Voltage Directive (2006/95/EEC)
EN 60950-1: 2001

Individual plug-in cards for wired and wireless connectivity will have their own certifications from their manufacturers. Information is available on each card's label.

Information regarding configuration of this equipment for operation on the telephone networks of the EC countries may be found in the Comrex ACCESS Portable product manual.

Contact person: Thomas O. Hartnett, Technical Director

Signed:  _____

Date: 02 July 2007